

TEST TARGET

(IEC61000-4-2)

Model 949



Operating Instructions

5/09



electro-tech systems, inc.

www.electrotechsystems.com

3101 Mt. Carmel Avenue, Glenside, PA 19038 • Tel: (215) 887-2196 • Fax: (215) 887-0131

1.0 DESCRIPTION

The Model 949 Test Target is a current transducer that measures the discharge current waveform of an ESD pulse from an electrostatic discharge simulator. The Model 949 is made in accordance with the design specified in IEC61000-4-2. It has a relatively flat frequency response out to 2.5 GHz. The transconductance is 1.0 Amp/Volt into a 50-Ohm load. The Model 949 is fabricated from silver-plated brass to provide very low surface resistance. The electrical schematic is shown in Figure 1.0-1.

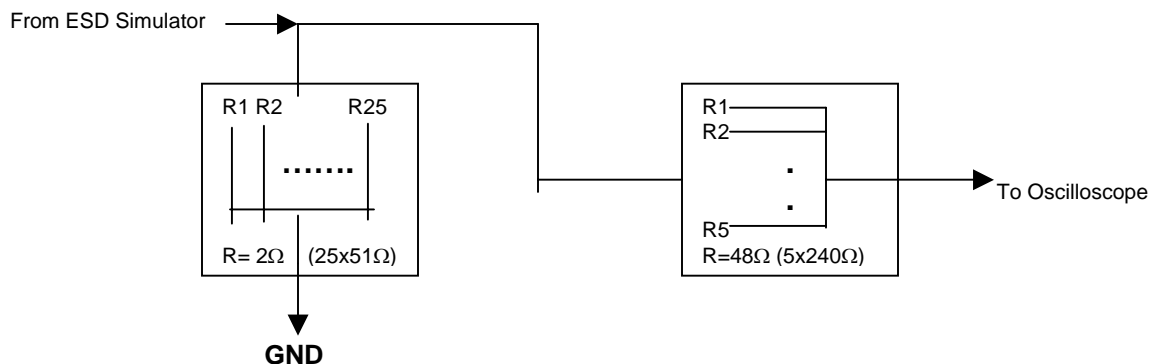

Figure 1.0-1: Test Target schematic

IEC 61000-4-2 specifies that the Test Target be mounted in the center of a 60x60" (1.5x1.5m) x 0.062" (3mm) plate. To meet the ESD simulator waveform specified, the simulator should be located approximately 39" (1m) from the Test Target and be connected by a 78" (2m) ground cable. An oscilloscope having a single shot bandwidth of 1 GHz and at least a 2GS/sec sampling rate is required.

For measuring HBM waveforms as specified in Mil Std 883C, Method 3015.7 (also ESDA STM 5.1 and JEDEC 114 specifications) the output and ground cables should be as short as practical.

For measuring MM waveforms as specified in ESDA STM5.2 the ground cable should be as short as possible.

2.0 INSTALLATION

The basic installation of the Model 949 Test Target consists of mounting it in the center of a 60x60" (1.5x1.5m) plate **that is supplied** by the user. The Test target can be installed on other types of surfaces or even be used alone, but the waveform characteristics specified for the 150pf/330Ω and other similar IEC style networks (Resistor and Capacitor in series before the discharge relay closure.) may not be met. HBM and MM waveforms may not require the large plate.

Drill a 1.5" (38mm) hole in the center of the plate and eight (8) 0.156" (4mm) mounting holes equidistant around the circumference of 2.36" (60mm). Install the Test Target from the rear using the 8, #6-32 screws and lock-washers supplied.

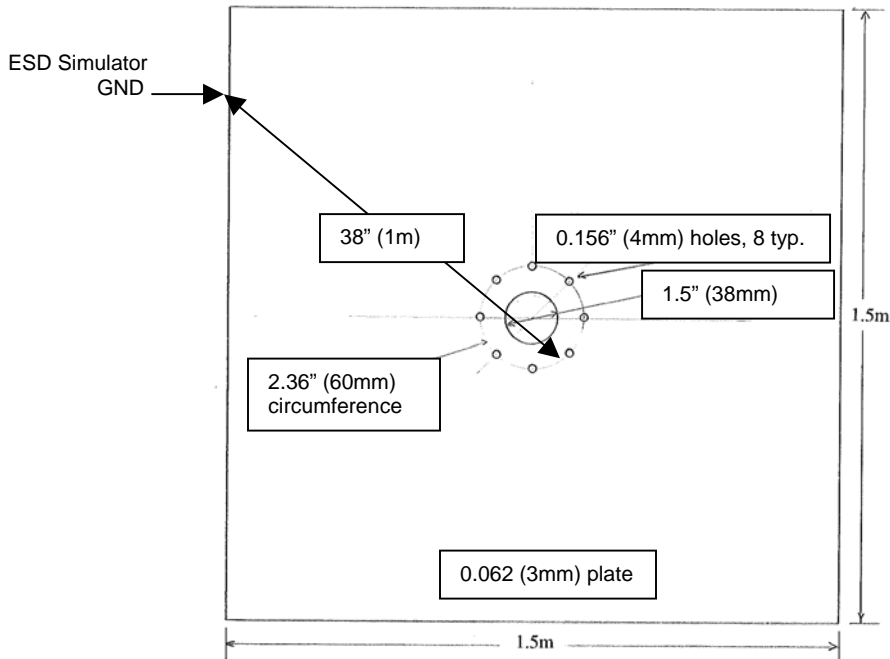

Figure 2.0-1: Ground Plane installation

3.0 OPERATION

Connect one end of the 3' (1m) male N-connector to BNC cable to the mating N-connector on the Test Target. Connect the BNC connector to the oscilloscope. If the scope has a 50-Ohm input, select the 50Ω. Otherwise, connect a 50Ω terminator between the cable BNC and scope input. If an attenuator is used, place it between the cable and 50Ω terminator. Connect the 2m ground return cable from the ESD simulator 39" (1m) from the center of the Test Target as shown in Figure 2.0-1 above. This must be the cable used to perform the actual testing. It should be arranged to form a large a loop possible away from the ground plane. Figure 3.0-1 is a functional block diagram of the calibration set-up.

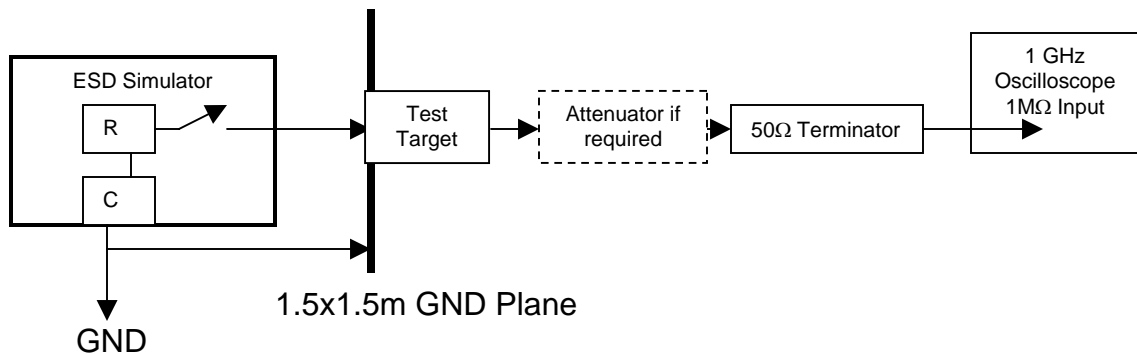

Figure 3.0-1: Calibration set-up functional block diagram

The center discharge disc of the Model 949 has a 6-32 tapped hole. This enables the user to use it as touch point for the output probe of the ESD simulator or to

attach a banana jack so that a cable output from the ESD simulator having a banana plug or a clip lead can be connected directly to the Test Target.

NOTE:

The thread of the banana jack must be cut to no longer than 1/8" (3mm) so as not to damage the internal resistor network. Failure to follow this precaution will void the Test Target warranty.

Initiate a discharge and observe the resulting waveform on the oscilloscope.

When checking the calibration of the ESD simulator for compliance with IEC 61000-4-2 the resulting waveform should look similar to the waveform shown in Figure 3.0-1a. When checking for compliance with Mil Std 883C, Method 3015.7, Notice 8 the waveform should look like that shown in Figure 3.0-1b.

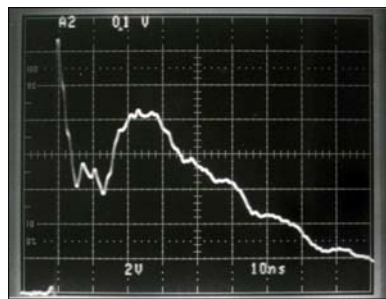

a.

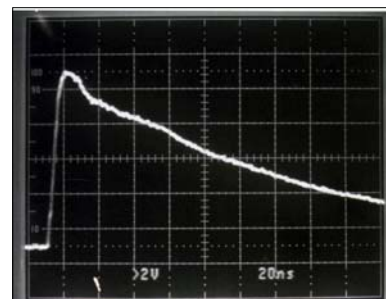

b.

All "a." waveforms are produced when the capacitor only is contained within the CAPACITOR module and the resistor is contained in the RESISTOR assembly that is plugged into the nose of the ESD Simulator. All "b" waveforms are produced when both the capacitor and resistor are contained in the CAPACITOR module and a "0" Ohm resistor is plugged into the nose. This configuration is generally referred to as the IEC style waveform. All waveforms are obtained using an IEC specified test target (ETS Model 949).

Figure 3.0-1: Typical ESD simulator discharge waveforms

4.0 WARRANTY

Electro-Tech Systems, Inc. warrants its equipment, its accessories and parts of its manufacture to be and remain free from defects in material and workmanship for a period of one (1) year from the date of invoice., ETS will, at it's discretion, either replace or repair without charge, F.O.B. Glenside, similar equipment or a similar part to replace any equipment or part of its manufacture which, within the above stated time, is proved to have been defective at the time it was sold. All equipment claimed defective must be returned properly identified to the Seller (or presented to one of its agents for inspection). This warranty only applies to equipment operated in accordance with Seller's operating instructions.

Seller's warranty with respect to those parts of the equipment that are purchased from other manufacturers shall be subject only to the manufacturer's warranty. The Seller's liability hereunder is expressly limited to repairing or replacing any parts of the equipment manufactured by the manufacturer and found to have been defective. The Seller shall not be liable for damage resulting or claimed to result from any cause whatsoever.

This warranty becomes null and void should the Resistance/Resistivity Kit, or any part thereof, be abused or modified by the customer or if used in any application other than that for which it was intended. This warranty to replace or repair is the only warranty, either expressed or implied or provided by law. It is in lieu of all other warranties and the Seller denies any other promise, guarantee, or warranty with respect to the equipment or accessories and, in particular, as to its or their suitability for the purposes of the buyer or its or their performance, either quantitatively or qualitatively or as to the products which it may produce. The buyer is expected to expressly waive rights to any warranty other than that stated herein.

ETS must be notified before any equipment is returned for repair. ETS will issue an RMA (Return Material Authorization) number for return of said equipment. Equipment should be shipped in the original packaging. If this is not possible, the equipment should be packed in a sufficiently large box of double wall construction with substantial packing around all sides. A description of the problem along with the contact name and telephone number must be included in formal paperwork and enclosed with the instrument. Electro-Tech Systems, Inc. will not assume responsibility for additional cost of repair due to damage Incurred during shipment as a result of poor packaging.