

Automatic Humidity Controller

Model 512 (Revision C)

Operating Manual

6/5/03

TABLE OF CONTENTS

1.0	INTRODUCTION	3
2.0	GENERAL DESCRIPTION	3
	2.1 Humidity Sensor	3
	2.2 Control Unit	4
	2.3 System Operation	4
3.0	SYSTEM DESCRIPTION	5
	3.1 Controller Front Panel	5
	3.1.1 Indicators	6
	3.1.2 Controls	6
	3.2 Controller Rear Panel	6
	3.2.1 POWER	7
	3.2.2 DEHUMIDIFY AC Output	7
	3.2.3 SENSOR IN	7
	3.2.4 REC. OUT	8
	3.3 Sensor/Cable	8
4.0	INSTALLATION	8
	4.1 Initial Check Out	8
	4.2 Installation	9
	4.2.1 Sensor	9
	4.2.2 Control Unit	10
	4.3 Operation	10
	4.3.1 Initial Turn On	10
	4.3.2 Setting RH SET POINT LEVEL	10
	4.3.3 Selecting Dehumidify or Humidify Functions	10
	4.3.4 Using the Model 514A as a Humidity Indicator Only	11
	4.3.5 Dehumidification and Humidification Systems	11
	4.3.6 Excessive Controller Cycling	11
5.0	CALIBRATION	11
	5.1 Control Unit Calibration	11
	5.1.1 Sensor Input	12
	5.1.2 Set Point	12
	5.1.3 LCD Meter	12
	5.1.4 Recorder Output	13
	5.2 Humidity Sensor Calibration	14
6.0	TROUBLESHOOTING	15
7.0	WARRANTY	17

1.0 INTRODUCTION

Many applications require the accurate measurement and precise control of relative humidity over a wide range in controlled environment test chambers. The Model 512-Rev C Automatic Humidity Controller may be used with any type of moisture sealed chamber. The controlled 115/230 VAC, 4 Amp output enables the Controller to control dehumidification systems that operate within the limits of the instrument's power handling capacity.

The Model 512 Rev C Controller is used where the control and measurement of humidity levels to an accuracy of $\pm 2\%$ R.H. or better is required. The unit can measure relative humidity over the entire range from 0 to 100% and can control the decrease in humidity to within $\pm 0.5\%$ R.H. of the humidity level set point.

The Automatic Humidity Controller was specifically designed to work in conjunction with the ETS Desiccant/Pump Dehumidification Systems (Models 561, 571 & 578). The Controller can also be used to operate dry gas systems utilizing an AC Solenoid valve to control the flow of gas or any other dehumidification system that operates within the Model 512-Rev C operating parameters.

The system can be used to control the humidity in virtually any sealed environment. However, it should be noted that the larger the chamber, the greater the variation in relative humidity throughout the chamber from the sensor reading. Good air circulation in the chamber helps maintain a uniform humidity level throughout the controlled environment.

NOTE: The user may proceed directly to Section 4.0 INSTALLATION & OPERATION

2.0 GENERAL DESCRIPTION

The Model 512-Rev C Automatic Humidity Controller consists of two (2) basic components: a Humidity Sensor and a Control unit.

2.1 Humidity Sensor

The standard Model 552 Humidity Sensor is a 2-piece unit with the sensing element mounted inside the chamber and an electronics module outside which is connected to the Control unit via a 5-foot multi-conductor cable. A capacitive sensing element whose capacitance is proportional to humidity is used to detect the relative humidity level. This type of sensor provides a fast response over the entire range of 0 to 100% R.H. Accuracy is $\pm 2\%$ R.H. from 0 to 90% R.H. and $\pm 3\%$ R.H. above 90% at 20° C.

The sensor assembly consists of a sensing element mounted in a 0.5 inch diameter ABS plastic cylinder, 2.5" long, with a plastic grid protecting the sensing element. The sensor is permanently connected to a separate electronics package measuring 4" L x 2.125" W x 1.187" D via a 12" cable. The sensor housing can be mounted to the wall of the chamber using an adhesive backed clamp or by mounting it in a 1/2 inch compression fitting inserted through the wall of the chamber. Other mounting configurations are available as options. This sensor has a temperature coefficient of 0.04% RH/°C.

The standard sensor cable length is 5' (1.5 m), terminated with a 3-Pin DIN connector. Other cable lengths or extensions up to approximately 12' (5 m) can be provided to meet special requirements.

2.2 Control unit

The Control unit provides the necessary indicators and controls to set the desired humidity level and to measure the actual humidity level in the chamber.

The front panel of the Control unit contains a 3 $\frac{1}{4}$ digit LCD readout for both determining the desired set point and for reading the relative humidity with a resolution of $\pm 0.1\%$ R.H. A momentary switch selects the information to be displayed. In the normal position the readout displays the measured relative humidity level and a Green LED is illuminated to indicate the READ R.H. function. In the depressed momentary position, the readout displays the desired humidity set point and a Red LED is illuminated to indicate the SET POINT function. When released, this switch automatically returns to the READ R.H. position. A 10-turn precision potentiometer is used to adjust the set point from 0 to 100% R.H.

A separate switch is provided for the Dehumidify function. When the DEHUMIDIFY switch is in the OFF position, the Model 514 operates as a precision electronic hygrometer.

The Control unit is housed in an ABS case measuring 8.25" W x 2.625" H x 9.0" D. (21 x 6.7 x 23 cm).

2.3 System Operation

Figure 2.3.1 is a block diagram illustrating the Automatic Humidity Controller used with the ETS Model 561 Dehumidification System installed in an ETS 500 Series Humidity Control Chamber.

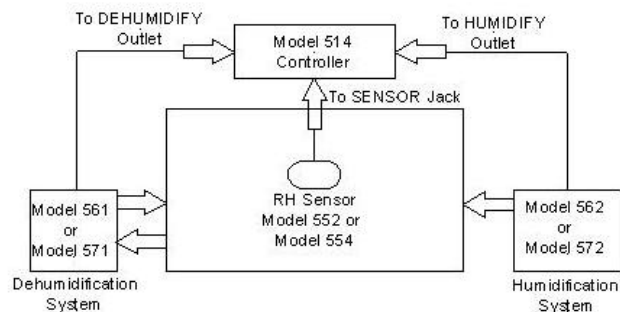

Figure 2.3-1 Controlled humidity chamber block diagram

The Humidity Sensor measures the relative humidity inside the chamber. The Sensor output signal is then compared to the set point. If the humidity measured in the chamber exceeds the set point by more than 0.5% R.H. the Controller turns on the pump which then circulates the

test chamber air through the desiccator. The desiccator absorbs moisture, thereby lowering the humidity level inside the chamber. When the set point humidity level is reached, the Controller turns off the pump. The pump will then cycle on and off automatically as required by the Controller to maintain the desired humidity level.

Power to operate the Dehumidification System is controlled by 4 amp solid-state relay. When the measured humidity deviates from the R.H. set point by 0.5%, the Controller turns on the relay which then supplies the necessary 115/230 VAC power to the system.

3.0 SYSTEM DESCRIPTION

3.1 Controller Front Panel

Figure 3.1-1 shows the indicators and controls located on the front panel of the Control unit. The following is a description of the function each indicator and control performs in the operation of the Automatic Humidity Controller.



Figure 3.1-1 Control Unit front panel

3.1.1 Indicators

3.1.1.1 % R.H.

This indicator is a 3 1/2 digit LCD readout that is used to display both the measured humidity and the desired humidity level set point.

3.1.1.2 HUMIDIFY

This indicator is a Green point source LED that shows the LCD meter is displaying the measured humidity.

3.1.1.3 SET PT.

This indicator is a Red point source LED that shows the LCD meter is displaying the set point.

3.1.1.4 DEHUMIDIFY

This indicator is a Green LED point source that shows that the DEHUMIDIFY control relay has been activated and the Dehumidification System is on.

3.1.2 Controls

3.1.2.1 READ RH/SET RH

This control is a 2-position, spring-loaded toggle switch. In the normal (Up) position, the measured humidity level is displayed on the LCD meter. When depressed to the SET RH position, the humidity level set point is displayed. Upon release, the switch returns to the READ RH position.

3.1.2.2 RH SET ADJ

This control is a precision 10-turn potentiometer used to select the desired humidity set point level. In the fully counterclockwise position (LO), the readout will indicate $0.00 \pm 0.2\%$ R.H. and in the fully clockwise position (HI) the readout will indicate $100.0 \pm 0.2\%$ R.H.

3.1.2.3 DEHUMIDIFY ON/OFF

This switch, when in the ON position, places the system in the DEHUMIDIFY mode. When the measured humidity is above the set point level, a control signal activates the DEHUMIDIFY relay circuit and 115/230 VAC is applied to the DEHUMIDIFY AC outlet on the rear panel of the Controller. This turns on the Dehumidification System. When this switch is in the OFF position the Dehumidification System will remain off irrespective of the RH level measured.

3.2 Controller Rear Panel

Figure 3.2-1 shows the switches, connectors and fuses located on the rear panel of the Control Unit. The following is a description of each component function:

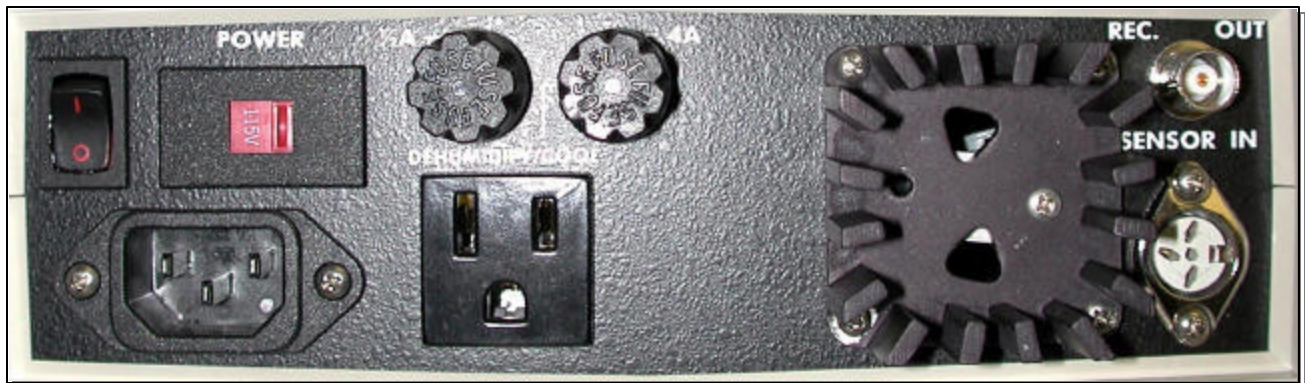

Figure 3.2-1 Control Unit rear panel

3.2.1 POWER

The Power switch, Fuse and AC line input connector are separate components that control the power input to the Model 512-Rev C Controller. The AC line cord receptacle is a standard IEC type. The

line cord supplied with the unit is eight (8) feet long with a standard North American grounded plug. Optional line cords are available which conform to the requirements of other countries when ordered with the Controller.

An input voltage select switch enables the Model 512-Rec C to operate from either 115 VAC or 230 VAC, 50/60 Hz.

CAUTION: Failure to set this switch to the corresponding AC line voltage in use can result in damage to the Humidity Control System.

The ON/OFF switch located on the rear panel, controls the ON/OFF status of the Controller. The AC line fuse, located on the power module, protects only the Controller electronics. It is a 3AG Slo Blo type rated at 250 Volts, ½ Amps. for 115 and ¼ amps for 230 VAC operation. The solid state relays are not voltage dependent and are capable of switching 4 Amps at either voltage. It is fused separately with a 4 amp, 3AG fuse for 115 VAC. It is recommended that the fuse rating be halved when using 230 VAC.

NOTE: 115 VAC pump must be used with a 115 VAC Controller and a 230 VAC pump must be used with a 230 VAC Controller.

3.2.2 DEHUMIDIFY AC Output

This AC output receptacle accepts the standard North American grounded plug. When the measured humidity exceeds the humidity level set point by about 0.5% R.H., 115/230 VAC power is applied to the receptacle. The maximum current that this circuit can continuously supply is 4 Amps.

3.2.3 SENSOR IN

This connector provides the input/output interconnect between the Controller and the Humidity Sensor. It is a standard 5-Pin DIN female receptacle with the following pin-out configuration:

Pin-1	R.H. Signal In (0-1VDC)
Pin-2	Ground
Pin-3	+22 VDC Unregulated
Pin-4	NC
Pin-5	+ 5VDC (Not used for 512-Rev C)

3.2.4 REC. OUT

This 4-Pin DIN connector enables the Controller to be connected to a chart recorder or connected to a computer through an appropriate data conversion interface for a permanent record of the measured humidity. The 0 to 0.5 Volt output signal, corresponding to the humidity range of 0-100%, is at Pin 1. GND is at Pin 2.

3.3 Sensor/Cable

The humidity sensor is supplied prewired from the factory with a 5' (1.5 m) cable with a 3-Pin DIN connector for the standard Model 552. Cable lengths up to 12 feet may be used if required. If the cable length is altered by the user, the humidity sensor wiring as shown in Figure 3.3-1 must be followed.

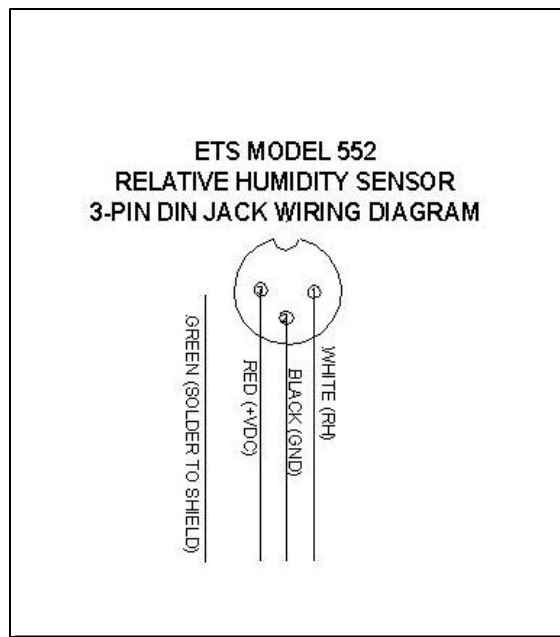

Figure 3.3-1 Connector wiring

4.0 INSTALLATION AND OPERATION

4.1 Initial Check Out

Unpack the Control Unit and Sensor and inspect for visible damage. If no damage is observed then proceed to check out the system as follows:

1 Check the line voltage setting by checking the Voltage Select switch and the fuse size. If another line voltage is desired, change the fuse and slide the Voltage Select switch to the appropriate voltage.

1. Disconnect AC power before attempting to change the voltage selector.
2. All equipment being used with the Controller must match the voltage selected.

2 Connect the Humidity Sensor to the Control unit by plugging in the DIN cable connector to the HUMIDITY SENSOR connector located on the rear panel.

3 Connect the line cord to the Controller AC LINE INPUT and plug the other end into the appropriate power outlet. Be sure the Controller POWER and DEHUMIDIFY control switches are in the OFF position.

4 Turn on the Controller. The LCD readout should read some humidity level and the Green HUMIDITY indicator should be lit.

5 Gently breathe onto the Humidity Sensor. The LCD reading should immediately increase, then slowly return to approximately the original reading.

6 Depress the READ RH/SET RH Switch to the SET RH position. The Display should read some level and the Red SET PT indicator should be lit. While holding the switch down in the SET RH position, rotate the RH SET ADJ. control fully counterclockwise. The LCD display should read $00.0 \pm 0.2\%$ RH. Rotate the RH SET ADJ. control fully clockwise. The Display should now read $100.0 \pm 0.2\%$ R.H.

7 Release the switch so that it returns to the READ RH position and note the humidity level reading on the Display. Turn on the DEHUMIDIFY Switch. Depress the READ RH/SET RH Switch to the SET RH position and rotate the RH SET ADJ. control until the same reading as the measured humidity level is obtained. When the SET PT is set above the actual RH reading the Green LED indicator light will be off. When the SET PT is set below the actual RH reading the Green DEHUMIDIFY indicator light will come on.

8 Plug the pump, or other controlled device, into the AC OUTPUT receptacle and repeat the test in 4.1.7. If the system passes the above preliminary checkout, it may then be installed into the test chamber.

4.2 Installation

4.2.1 Sensor

The Humidity Sensor should be positioned in the test chamber to sense the best average humidity condition within the chamber. The sensor is normally installed using either the supplied clamp or through the bulk head compression fitting supplied with the ETS 500 Series Chambers.

For other installations, a 0.562 inch hole is required to pass the sensor through the environmental chamber wall. The electronics module should be mounted outside the chamber using the supplied Velcro.

The hole should be carefully sealed using the supplied moisture-proof sealing compound.

CAUTION

The sensing element is contained in a probe assembly protected against mechanical damage by a slotted housing cover. Under no circumstances should the sensing element be touched. The probe should never be cleaned using compressed air. Dust and dirt particles can be removed by blowing gently. Use distilled water or vinegar and a cotton swab ONLY to clean the element.

4.2.2 Control Unit

The Control Unit may be placed on any surface near the test chamber. A suggested location is on top.

Connect the sensor cable to the SENSOR IN connector located on the rear panel of the Controller. Plug the Dehumidifier into the AC OUTPUT receptacle. Plug the line cord into the appropriate power outlet (115 or 230 VAC). The Model 514C Automatic Humidity Controller is now ready for operation.

4.3 Operation

4.3.1 Initial Turn On

Turn on the Controller. (The POWER switch is located on the rear panel.)

4.3.2 Setting R.H. SET POINT LEVEL

Depress the READ/SET R.H. switch to the SET R.H. position and adjust the R.H. SET ADJ control for the desired R.H. set point as indicated on the LCD display. During this adjustment, the Red LED will be on. When the correct reading is obtained, release the switch. The display will read the measured humidity level.

4.3.3 Activating Dehumidify Function

If the desired humidity is lower than the humidity initially measured turn on the DEHUMIDIFY function by moving the rocker switch to the ON position. The Green DEHUMIDIFY light will come on indicating that the Dehumidification System has been activated.

As the humidity level in the test chamber begins to drop it will be instantly detected by the Humidity Sensor and be displayed on the LCD meter. When the humidity level in the chamber has been reduced to the set-point level, the Green LED light will go out indicating the Dehumidification system has been turned off. As the humidity level in the chamber gradually begins to increase above the set-point level, the Dehumidification System will turn back on until the humidity level drops back to slightly below the set point. The System will continue to cycle to maintain the desired humidity.

4.3.4 Using the Model 512-Rev C as a Humidity Indicator Only

If the Model 512 Rev C Controller is to be used as a humidity indicator only (no humidity control), turn the DEHUMIDIFY switch to OFF. The system now becomes a humidity level meter (hygrometer) only.

4.3.5 Dehumidification Systems

The Model 512 Rev C Controller will control any dehumidification system that operates within its power handling capability. The ETS Models 561, 571 & 578 Pump/Desiccator Dehumidification Systems and the ETS Model 563 Dry Gas Dehumidification System are described in detail in their appropriate Operating Manuals.

4.3.6 Excessive Controller Cycling

Frequent on/off cycling of the dehumidifier may be indicative of a poor test chamber seal or defective gloves. The chamber should be thoroughly inspected to determine where the leak(s) are occurring and the problem corrected.

5.0 CALIBRATION

The Model 512-Rev C Automatic Humidity Controller is calibrated prior to leaving the factory. However, as with all temperature and humidity measuring instruments, they must be calibrated periodically to maintain specified performance levels. Calibration should be checked at least one or two times a year depending on the operating conditions and the required measurement accuracy.

NOTE: If returned to the factory for recalibration or repair a RMA number must be first obtained by calling 215-887-2196 Ext. 220.

Complete calibration of the Model 512 Rev C is performed in two parts. The first part requires calibration of the Control Unit only. The second part requires calibration of the complete system.

5.1 Control Unit Calibration

Figure 5.1-1 is a diagram showing the location of the calibration adjustment points on the Controller printed circuit board. To gain access to the board, remove the 4 screws on the bottom cover holding the top and bottom of the case together. Remove the top and bottom covers.

A calibrated digital voltmeter with 0.1 millivolt resolution and a 1.0 VDC power source are required.

Connect the Power source to Pin-1 of the SENSOR input DIN connector.

Turn on the power and allow several minutes for the instrument to warm up. Place the DEHUMIDIFY switch in the OFF position, then follow the procedure below:

5.1.1 Sensor Input Calibration

1. Zero Offset Adjust – This calibrates the sensor input at 0% RH.
 - a. Set the Power source to 0.00 V (ground).
 - b. Connect the Black common lead from the DVM to the black test jack on the PCB (located to the left of C3 on the right side of the PCB).
 - c. Touch the Red lead from the DVM to Pin-6 of U3.
 - d. Adjust R9 until the DVM reads 0.00 mV.

3. Full Scale Calibration – This calibrates the sensor input at 100% RH.
 - a. Adjust the power source to 1.000 VDC. (To verify the 1.000 VDC reading on the PCB measure the voltage at the lead of R13 going to JP1).
 - b. Touch the Red lead of the DVM to Pin-6 of U3.
 - c. Adjust R8 to obtain a reading of 5.000 VDC on the DVM.

4. Alternately repeat steps 2 and 3 until both conditions are met.

5.1.2 Set-Point Calibration

The 1 VDC power source is not used for this part of the calibration procedure, but should remain plugged into the SENSOR input.

1. Zero offset adjust – This calibrates the set point range at 0% RH.
 - a. Turn the 10-turn SET ADJUST control on the front panel fully counterclockwise.
 - b. Connect the Black common lead of the DVM to the Black test jack on the PCB.
 - c. Touch the Red DVM lead to Pin-6 of U2.
 - d. Adjust R5 until the DVM reads exactly 0.00 mV.

2. Full scale adjust – This calibrates the set point range at 100% RH.
 - a. Turn the 10-turn SET ADJUST control on the front panel fully clockwise.
 - b. Touch the Red DVM lead to Pin-6 of U2
 - c. Adjust R6 until the DVM reads exactly 5.000 V.

3. Alternately repeat steps 1 and 2 until both conditions are met.

5.1.3 LCD Display Calibration

This step requires the 1 VDC power source. The sensor input calibration must be completed prior to performing the display calibration.

1. Adjust the power source to 1.000 VDC and verify

2. Adjust R1 until the LCD display reads exactly 100.0.

3. Turn the 10-turn SET ADJUST control fully clockwise. Press the READ/SET switch to the SET position. The set point will now be displayed on the LCD meter. It should read 100.0.

4. Repeat the R1 adjustment if necessary to obtain the 100.0 reading.

5. Repeat steps 1-3 until both switch settings display exactly 100.0.

5.1.4 Recorder Output Calibration

This adjustment calibrates the RECORDER OUT signal which is 0-500 mV corresponding to 0-100% RH.

- a. Adjust the power source to 1.000 VDC and verify.
- b. Touch the DVM red lead to Pin-1 of J9.
- c. Adjust R7 until the DVM read 500 mV. The recorder output signal is now calibrated for 5 mV/% RH.

Comparator and Humidity Readout Calibration Test - Using the same test set-up as above, set the power supply for an output of 0.25 ± 0.01 V. The display should read $25.0 \pm 0.2\%$ R.H. Depress the READ./SET switch and adjust the set point to obtain the same exact reading as above. Vary the R.H. SET ADJ control by $\pm 1\%$ R.H. The DEHUMIDIFY light should turn on and off within $\pm 0.5\%$ R.H. of the set point.

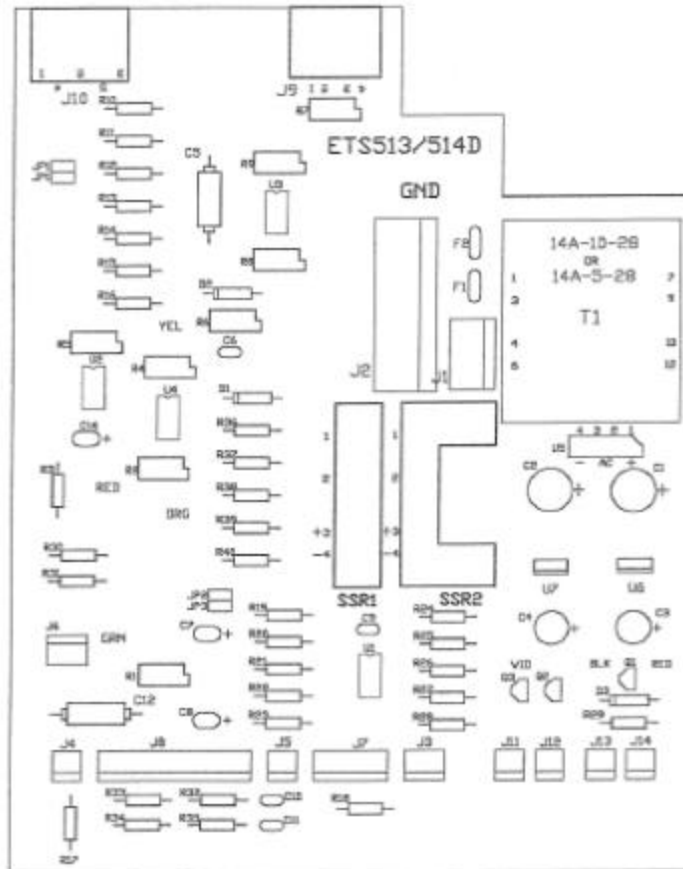

Figure 5.1-1 Calibration adjustment points on the Controller printed circuit board

The above test can be repeated for 50.0% R.H. (0.50V) and 75.0% R.H. (0.75V) to check the calibration at these humidity points. The above procedure completes the calibration of the Control Unit portion of the system.

5.2 Humidity Sensor Calibration

Calibration of the Humidity Sensor requires either a known calibrated reference sensor for comparison or certified calibration salt solutions.

Field calibration of the Humidity Sensor can be performed by comparing the Model 512-Rev C relative humidity reading with a known calibrated reference. The reference sensor should be placed next to the Model 512-Rev C sensor and allowed to stabilize for at least 30 minutes before making any adjustments to the sensor electronics.

The Humidity Sensor calibration can be performed either in the test chamber or in a separate calibration chamber following the procedure below:

1. Remove the Sensor from its mounted position. If the Sensor is to be calibrated in the chamber place the reference sensor next to it. If the Sensor is to be calibrated outside the chamber, remove the Sensor and the electronics module (Model 552) from their installed positions. The electronics unit is held in place by Velcro. Remove the screws holding the cover of the electronics unit to gain access to the adjustment controls.
2. Connect the Sensor to the Control unit and turn on the power. Allow at least 5 minutes for the system to warm up. The Sensor and reference unit must be in a constant temperature environment of 73°F/23°C $\pm 5/3^\circ$ for at least 30 minutes to obtain temperature equilibrium prior to calibration.
3. Establish a 12% relative humidity level in the chamber.
4. Read the temperature and relative humidity. Compare the reference unit reading with the level displayed on the previously calibrated Humidity Controller display. They should be within $\pm 2\%$ R.H. of each other. If not adjust the "1-point RH-calibration" (zero offset) control as shown in Figure 5.1-2 to obtain the correct reading.
6. Establish a 75% relative humidity level for at least 30 minutes then read the temperature and relative humidity. Compare the readings. They should be within $\pm 2\%$ R.H. of each other. If not, adjust the "for factory use only" (span adjust) control to obtain the correct reading.
7. Recheck the low humidity calibration and repeat the above procedure if necessary. It may require repeating the procedure several times until proper calibration at both ends is achieved.

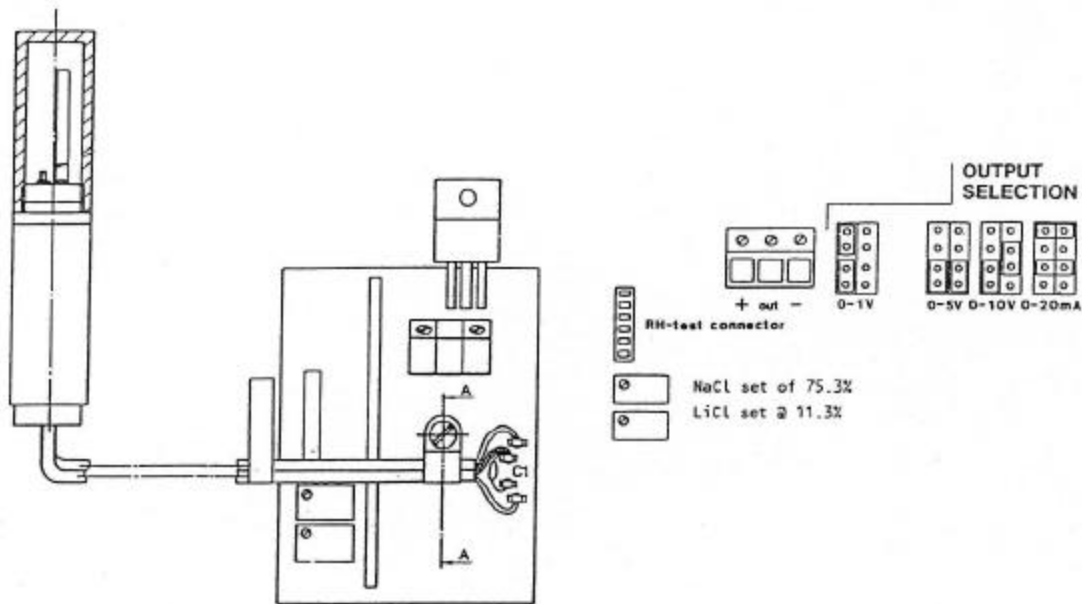

Figure 5.1-2 Model 552 R.H. Sensor calibration adjustment location

This completes the calibration of the Model 512-Rev C Automatic Humidity Controller.

Other calibration techniques include the use of wet bulb/dry bulb and chilled plate measurement techniques. Wet bulb/dry bulb instruments should not be used in the test chamber because the wet bulb adds humidity to the chamber making it extremely difficult to calibrate at low humidity levels. However, there are wet bulb/dry bulb calibrators with a small test cell for the sensor that may be used.

6.0 TROUBLESHOOTING

The Model 512-Rev C is all solid state and should provide many years of trouble-free service. If a problem with the system is suspected, it is recommended that the fault be initially isolated to either the Sensor or the Control unit.

The following troubleshooting guide should assist the user in locating the more obvious problems:

1. No Power - Check Controller Fuse (1/2 Amp at 115 VAC, 1/4 Amp at 230 VAC). Check power at the wall outlet.
2. Power (LEDs light), but no indication on LCD display – LCD display defective or no ± 5 VDC. Return unit to factory.
3. Obviously Incorrect Humidity Reading - Blow gently onto Humidity Sensor and observe the reading. If small ($\pm 10\%$ R.H.) changes in humidity are observed, the Humidity Sensor is at least working. Depress the READ/SET R.H. switch and adjust the RH SET ADJ control fully CCW and then rotate it fully CW. The display should show readings of $00.0 \pm 0.2\%$ RH to $100.0 \pm 0.2\%$ RH. If not, proceed to paragraph 4.

To check the sensor input circuit to the Controller, connect a 0-1 Volt power source between Pins 1 (+) and 2 (-) of the HUMIDITY SENSOR IN connector. With a voltmeter, also measure the voltage between Pins 3 (+) and 2 of the Humidity Sensor. It should measure approximately 22 Volts.

Proper display and voltage readings indicate that the problem is in the Sensor Unit or cable. The Sensor must be returned to the factory for service.

If the correct voltage is measured, but the display gives an erroneous reading, replace U1 (Harris CA3140) in the Control Unit.

4. Incorrect RH Set Point Readings – With a voltmeter, check the voltages at U1. At Pin 4, the voltage measured should be –11.4 to -12.6 volts and at Pin 7 it should be +11.4 to +12.6 Volts. If either voltage is out of specification, return the unit to the factory for service. If the voltage checks okay, replace U2 (LM741 or equivalent). If the unit still fails to operate, return it to the factory.

5. No DEHUMIDIFY AC Control Voltage – Turn on the DEHUMIDIFY switch. Read the humidity level on the LCD display, then adjust the set point to that level. Rotate the control at least $\pm 1\%$ R.H. about this point. The Green DEHUMIDIFY indicator should come on when the set point is below the measured humidity. When the set point is above the measured humidity the Green indicator should be off. If the light cycles, but the dehumidifier still fails to operate either the solid state relay may be blown or the Dehumidification System may have failed.

Replace the comparator U1 (LM2903) and recheck the system. If the system still fails to operate, return the unit to the factory for repair.

Unit reads either 0 or over over 100% with sensor plugged in- Sensor defective, return to factory for repair or replacement.

If any components are replaced in the Model 512-Rev C, it will be necessary to recalibrate the system as set forth in Section 5.

7.0 WARRANTY

Electro-Tech Systems, Inc. warrants its equipment, accessories and parts of its manufacture to be and remain free from defects in material and workmanship for a period of one (1) year from date of invoice and will, at the discretion of Seller, either replace or repair without charge, F.O.B. Glenside, similar equipment or a similar part to replace any equipment or part of its manufacture which, within the above stated time, is proved to have been defective at the time it was sold. All equipment claimed defective must be returned properly identified to the Seller (or presented to one of its agents for inspection). This warranty only applies to equipment operated in accordance with Seller's operating instructions.

Seller's warranty with respect to those parts of the equipment which are purchased from other manufacturers shall be subject only to that manufacturer's warranty.

The Seller's liability hereunder is expressly limited to repairing or replacing any parts of the equipment manufactured by the manufacturer and found to have been defective. The Seller shall not be liable for damage resulting or claimed to result from any cause whatsoever.

This warranty becomes null and void should the equipment, or any part thereof, be abused or modified by the customer or if used in any application other than that for which it was intended. This warranty to replace or repair is the only warranty, either expressed or implied or provided by law, and is in lieu of all other warranties and the Seller denies any other promise, guarantee, or warranty with respect to the equipment or accessories and, in particular, as to its or their suitability for the purposes of the buyer or its or their performance, either quantitatively or qualitatively or as to the products which it may produce and the buyer is expected to expressly waive rights to any warranty other than that stated herein.

ETS must be notified before any equipment is returned for repair. ETS will issue an RMA (Return Material Authorization) number for return of equipment.

Equipment should be shipped prepaid and insured in the original packaging. If the original packaging is not available, the equipment must be packed in a sufficiently large box (or boxes if applicable) of double wall construction with substantial packing around all sides. The RMA number, description of the problem along with the contact name and telephone number must be included in formal paperwork and enclosed with the instrument. Round trip freight and related charges are the owner's responsibility.

WARNING

WOODEN CRATES MUST NOT BE USED. PACKAGING OF DELICATE INSTRUMENTS IN WOODEN CRATES SUBSTANTIALLY INCREASES THE CONTENT'S SUSCEPTIBILITY TO SHOCK DAMAGE. DO NOT PLACE INSTRUMENTS OR ACCESSORIES INSIDE OTHER INSTRUMENTS OR CHAMBERS. ELECTRO-TECH SYSTEMS, INC. WILL NOT ASSUME RESPONSIBILITY FOR ADDITIONAL COST OF REPAIR DUE TO DAMAGE INCURRED DURING SHIPMENT AS A RESULT OF POOR PACKAGING.